

DATE	REV	BY
08/15/18	A	A.L.

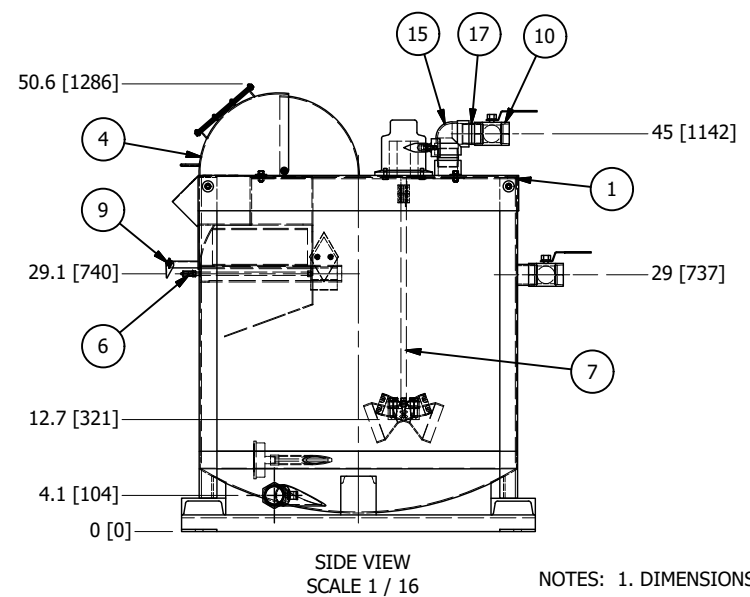
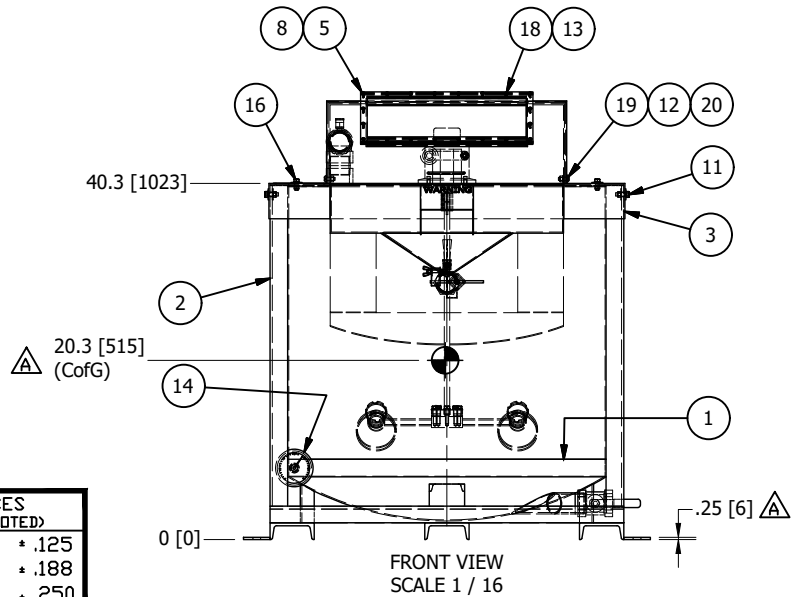
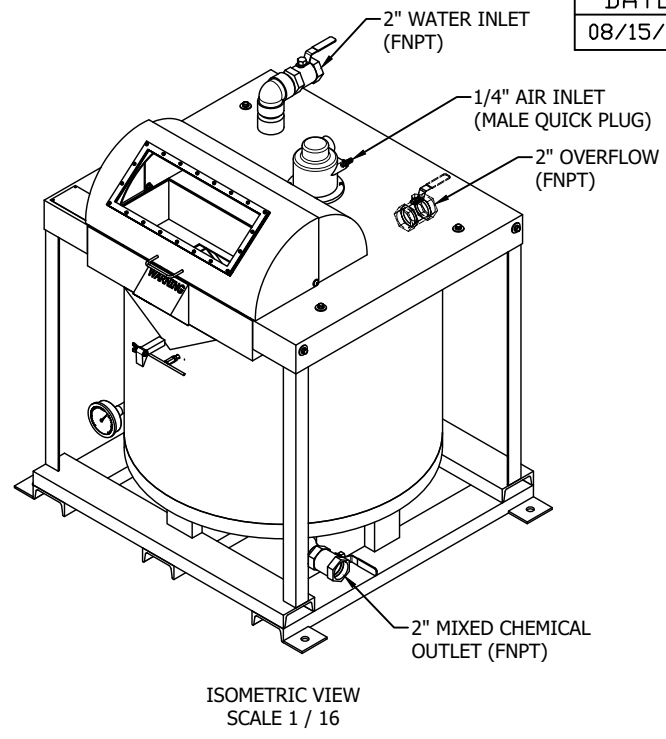
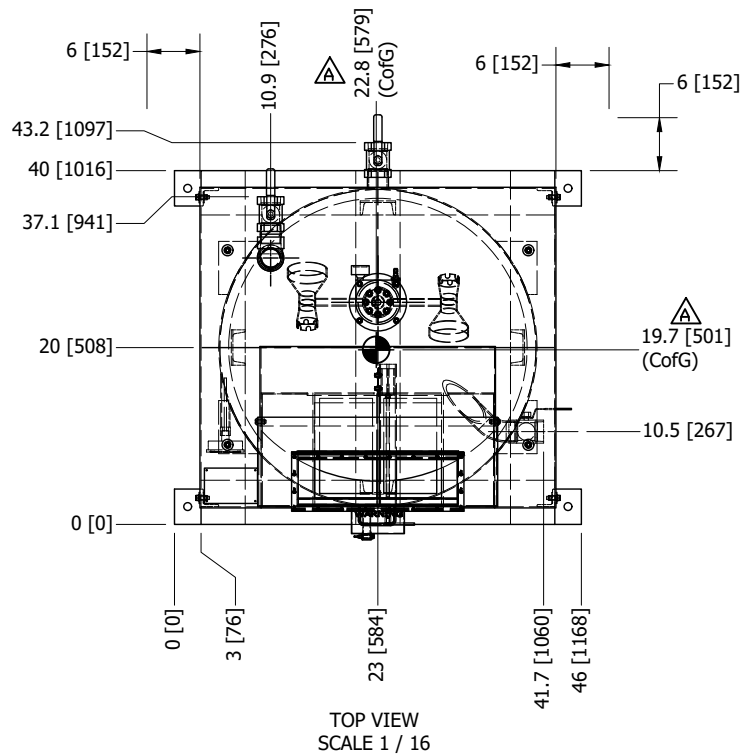

NOTES: 1. DIMENSIONS = INCHES [mm].

TOLERANCES (EXCEPT AS NOTED)	
3 PLACE DECIMALS	± .125
2 PLACE DECIMALS	± .188
1 PLACE DECIMALS	± .250

	Drawn By: A.LERMA Date: 06/26/14 Material: NOTED	Sheet No. SHEET 1 of 2	ESTIMATED WEIGHT 600 LBS. [270 kg]
	1234 N. Post Oak Ste.100 Houston, TX. 77055 Phone: 713-688-2008 Fax: 713-688-2993 www.cccmix.com	Title SAFECEM MIXING TANK 100 GALLON GENERAL ARRANGEMENT	Copyright: This drawing is not to be reproduced or modified in any way without expressed written consent from W.G. Lott-Compatible Components Corp.

DATE	REV	BY
08/15/18	A	A.L.

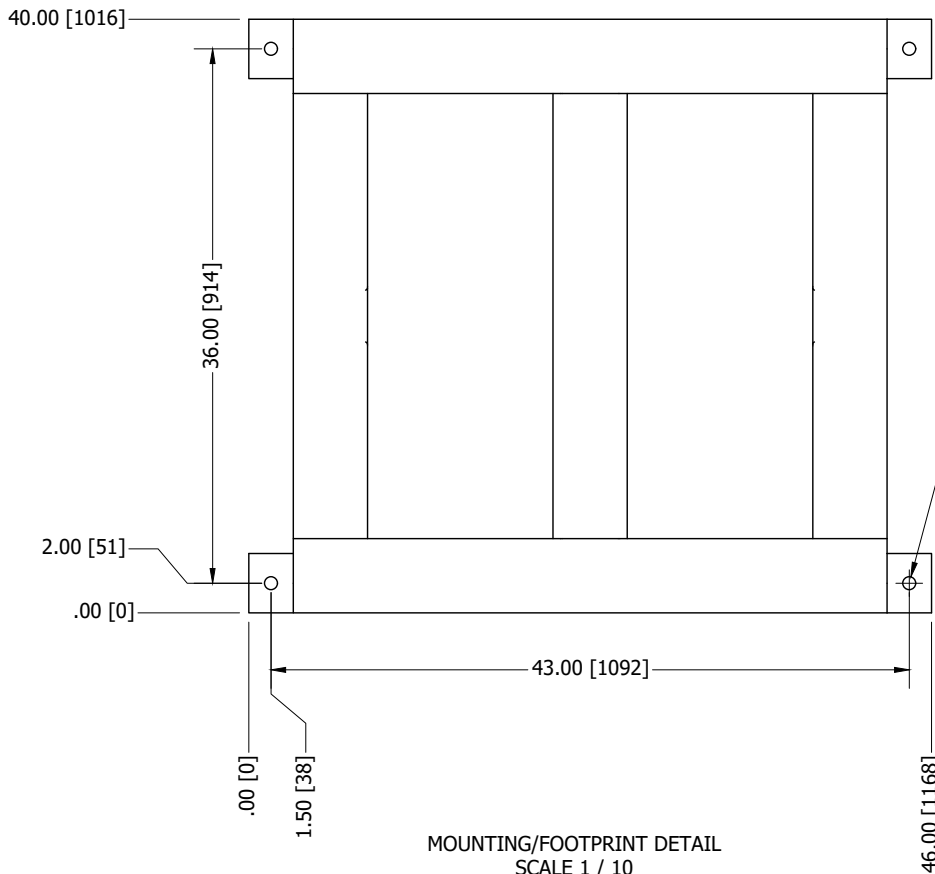

MOUNTING/FOOTPRINT DETAIL
SCALE 1 / 10

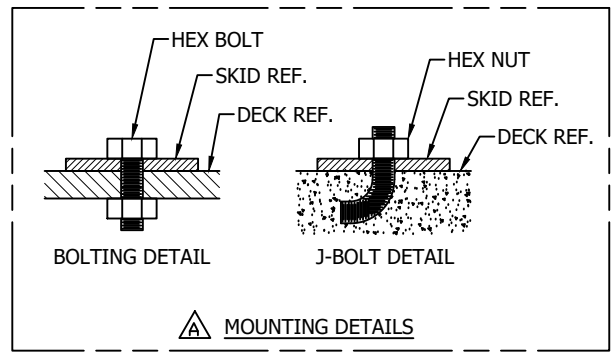

MOUNTING DETAILS

TOLERANCES
(EXCEPT AS NOTED)

3 PLACE DECIMALS	* .125
2 PLACE DECIMALS	* .188
1 PLACE DECIMALS	* .250

PARTS LIST				
ITEM	QTY	PART NUMBER	DESCRIPTION	MATERIAL
1	1	C-031514-01	DRUM WELDED ASSY, 36"	Stainless Steel
2	1	C-031514-08	BASE FRAME SKID ASSY.	Stainless Steel
3	1	C-031514-09	TABLE TOP WELDED ASSY, 36"	Stainless Steel
4	1	C-031514-12	DRUM HOOD W/VIEW WINDOW	Stainless Steel
5	1	C-031514-16	WINDOW CAP, 11-GA SHEET	Stainless Steel
6	1	C-031514-22	BAG SLITTER ASSEMBLY	Stainless Steel
7	1	C-031514-24	CONICAL MIXER, 4" (x2) 4 HP.	Stainless Steel
8	1	C-031514-26	WINDOW GASKET, 1/8"-THK.	Rubber
9	1	C-070714-07	BAG SLITTER LOCKING ASSEMBLY	Stainless Steel
10	3	C-BV-2-FT-304	VALVE, 2" BALL, FNPT	Stainless Steel
11	4	C-HXB-0.38-16-304-1.25	HEX BOLT, 3/8"-16 UNC x 1.25" LG.	Stainless Steel
12	10	C-HXN-0.38-16-304	HEX NUT, 3/8"-16 UNC	Stainless Steel
13	20	C-LW-N10-304	WASHER, #10 LOCK	Stainless Steel
14	1	C-TGB-0.5-MT-304	THERMOMETER, 5"x1/2" NPT, THERMOWELL AA-575R	Stainless Steel
15	1	STANDARD ITEM	ELBOW, 2" NPT 90	Stainless Steel
16	8	STANDARD ITEM	HEX BOLT, 3/8"-16 UNC x 1" LG.	Stainless Steel
17	2	STANDARD ITEM	NIPPLE, 2" NPT	Stainless Steel
18	20	STANDARD ITEM	ROUND HEAD SCREW, #10-24 UNC x 5/8" LG.	Stainless Steel
19	2	STANDARD ITEM	SOCKET CAP SCREW, 3/8"-16 UNC x 1" LG.	Stainless Steel
20	8	STANDARD ITEM	WASHER, 3/8" FLAT	Stainless Steel



Drawn By: A.LERMA Date: 06/26/14 Material: NOTED
 1234 N. Post Oak Ste.100
 Houston, TX. 77055
 Phone: 713-688-2008 Fax: 713-688-2993
 www.cccmix.com

Sheet No. SHEET 2 of 2
 Title: SAFECHEM MIXING TANK
 100 GALLON
 GENERAL ARRANGEMENT

ESTIMATED WEIGHT 600 LBS. [270 kg]
 Copyright: This drawing is not to be reproduced or modified in any way without expressed written consent from W.G. Lott-Compatible Components Corp.

Drawing No. C-CMT-100-01A